

# Axilok

## Unitized Wheel Bearing Nut System Installation and Removal Procedures

### Pre-Installation Procedure

Before installing Axilok, check the following:

- Inspect Axilok for two locking clips. Refer to Figure 1.
  - Each locking clip should be securely fastened to the nut body and have a rivet that passes through the top of the locking clip body.
  - Each locking clip should have a locking clip tab protruding completely through the retainer cage adjustment slot (when properly aligned and not compressed by a socket). Refer to figures 2, 3, and 4.
  - Locking clips should not be bent, cracked or broken.
  - Determine if you have slot style or D flat style axle and use appropriate Axilok product. See Figure 6.
- Inspect Axilok retainer cage condition.
  - There should be no cracks or other damage to the retainer cage.
  - Retainer cage should be secured to the nut body and not fall off when the locking clips are compressed by the socket.
  - The retainer cage tab or "D" flat should be free of damage, such as cracks, scarring, gouges or distortion. Refer to Figure 6.
- Inspect Axilok threads.
  - The threads should show no sign of wear or damage.
  - Wipe the threads to remove excess oil or debris.
- If Axilok fails any of the checks above, the Axilok is unfit for use. DO NOT USE. Replace the unfit Axilok with a new Axilok and repeat all checks.
- Free rotation inspection. This test will check for nut and socket compatibility.
  - With correct size six-point socket turned upside down, insert Axilok completely into the socket, compressing the locking clips. Refer to Figure 8.
  - Retainer cage should spin freely with no interference between locking clip tabs and retainer cage.
  - If locking clip tabs interfere with rotation of the retainer cage, the socket is not fully compressing the locking clips. This indicates that the socket is the incorrect size, worn or out of specifications and must be replaced.

### WARNING

Failure to observe the following warnings can result in separation of the wheel from the vehicle, creating a risk of death or serious injury.

This Axilok product is not compatible with all axles currently in use. Do not use this Axilok product on an incompatible axle. Review axle or vehicle manufacturer's literature to determine if the Axilok product is compatible. Inappropriate use could produce a "wheel off" condition, which may result in serious bodily injury and/or equipment failure.

If Axilok has not been selected as standard equipment by the Original Equipment Manufacturer (OEM), do the following: Review axle manufacturer's bulletins to be sure axle is compatible with Axilok.

AXILOK	Part Number	Socket Size 6-Point	Initial Torque (in lbs/ft)	Initial Backoff	Final Torque (in lbs/ft)	Final Backoff	Increments of Adjustment (per slot)
AX-12-1500D	39129	2 1/8"	200	1/2 turn	75	1/10 turn	0.0038"
AX-18-1500	39131	2 1/8"	200	1/2 turn	75	1/10 turn	0.0025"
AX-12-1750D	39121	3 1/4"	200	1/2 turn	75	1/10 turn	0.0030"
AX-12-2625	39023	3 1/4"	200	1/2 turn	75	1/10 turn	0.0030"
AX-16-2625	39025	3 1/4"	200	1/2 turn	75	1/10 turn	0.0022"
AX-12-3250	39043	4"	200	1/2 turn	75	1/10 turn	0.0023"
AX-12-3480	39026	4 1/8"	200	1/2 turn	75	1/10 turn	0.0023"

See Installation Procedure for Full Details

AXILOK Part Numbers and Installation Torque  
TABLE 1.



Place Axilok in correct size socket and check for free rotation.

FIGURE 8.



Start Axilok by hand

FIGURE 9.



Torque Axilok to initial torque value while rotating hub to properly seat bearings.

FIGURE 10.

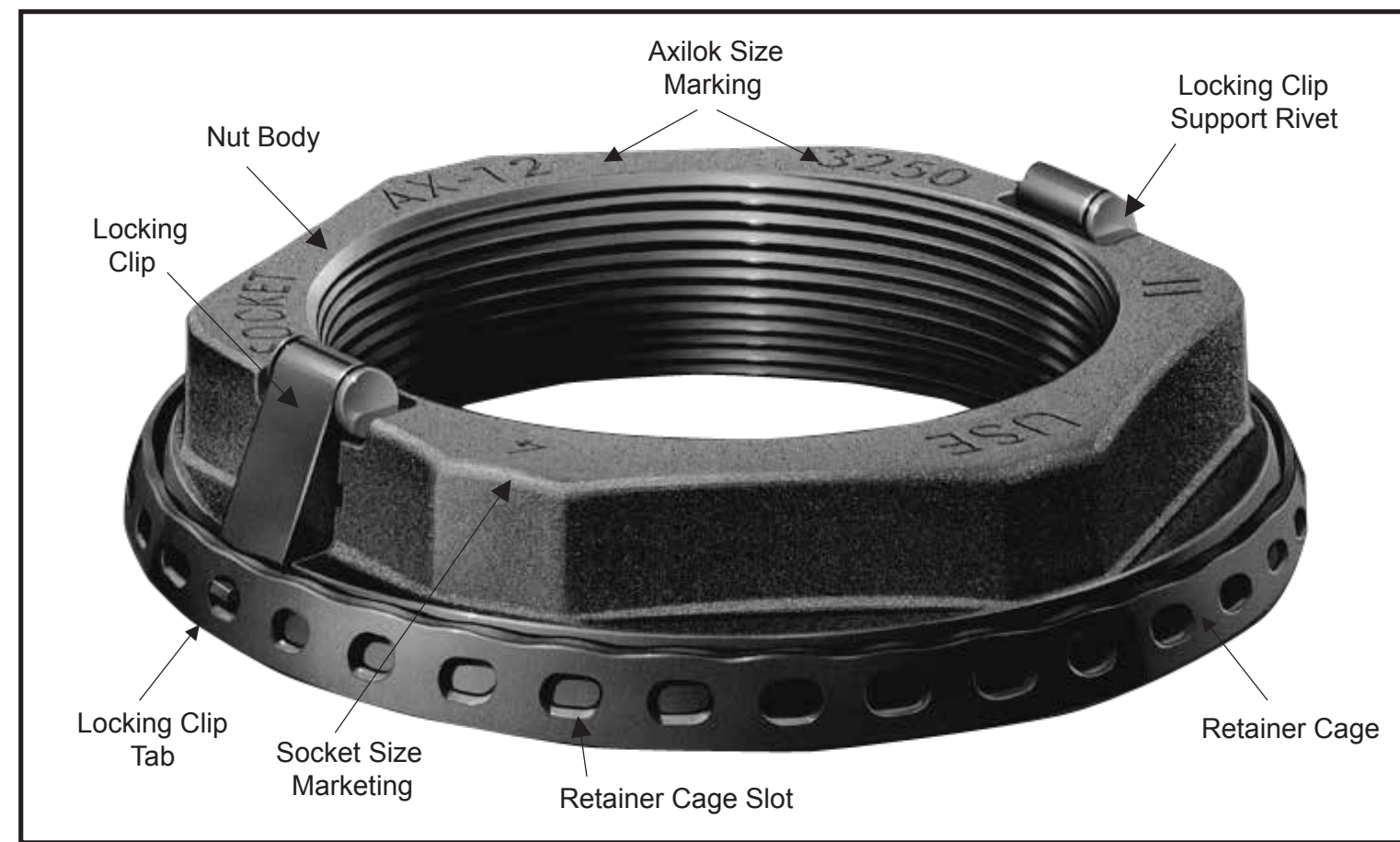

AXILOK Component View  
FIGURE 1.

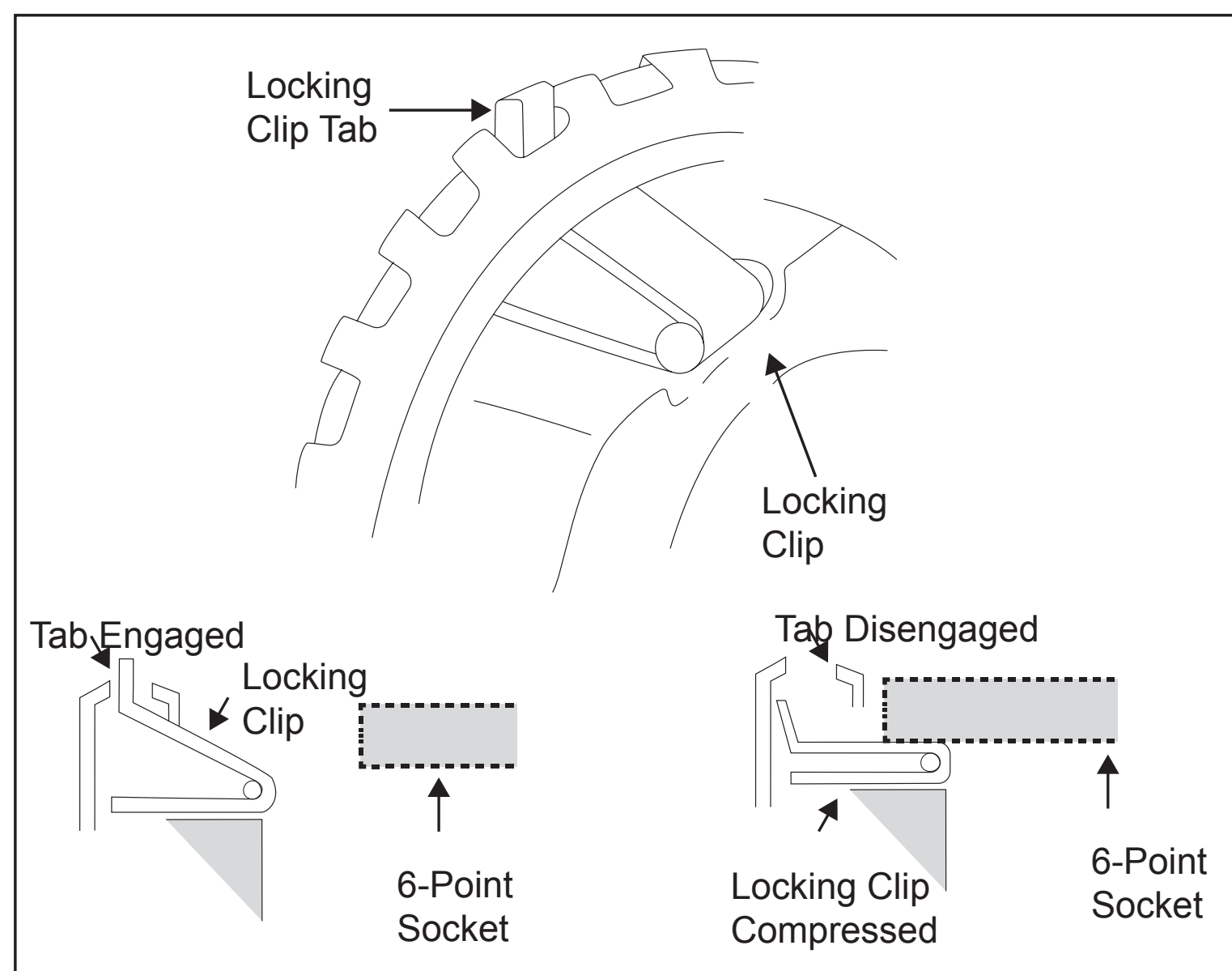

Checking Position of Locking Clip Tabs  
FIGURE 2.

\*Light burnishing of the retainer cage bearing surface after use is normal.

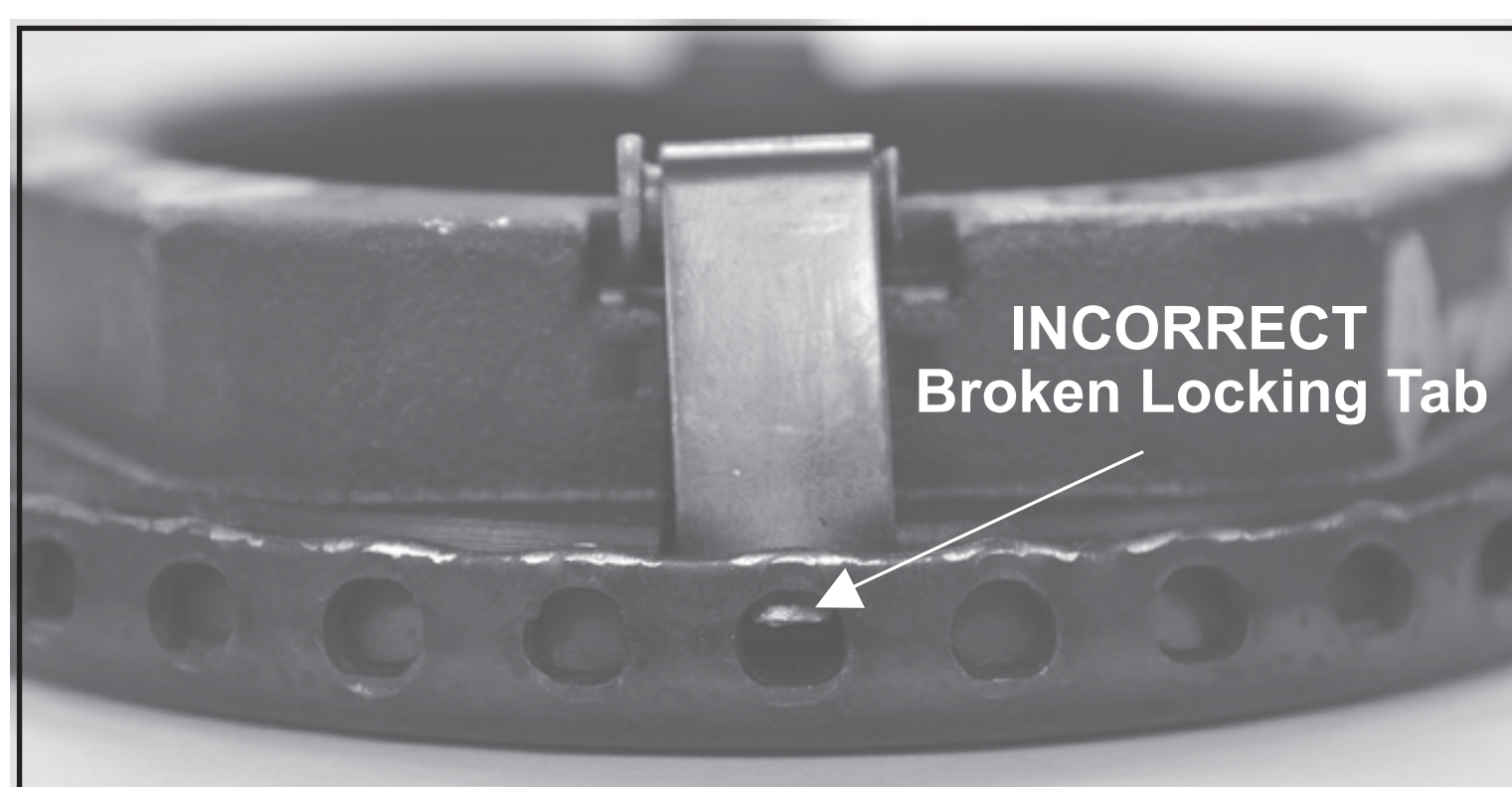

Locking Clip Tabs Broken  
FIGURE 3.

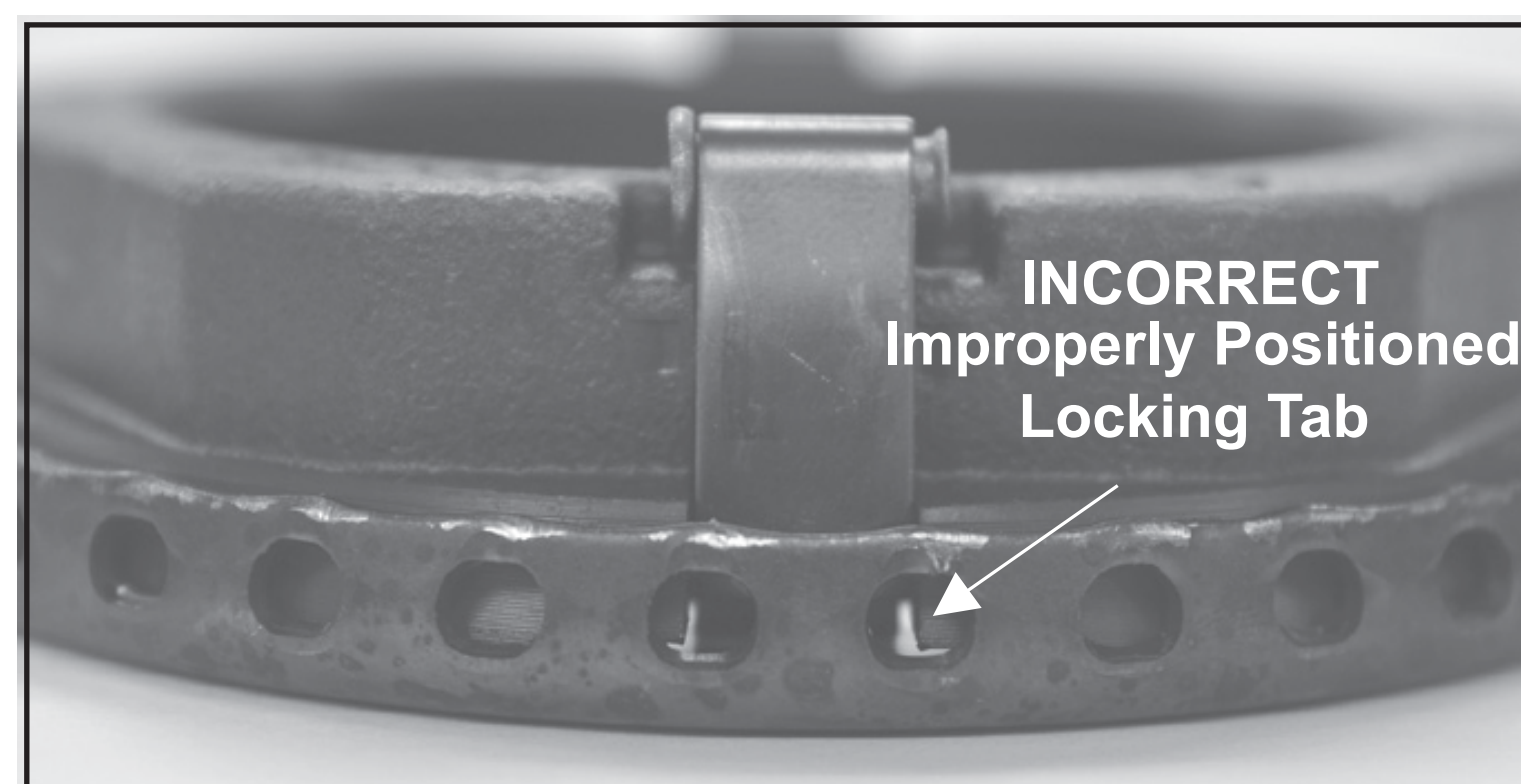

Locking Clip Tabs Improperly Positioned  
FIGURE 4.

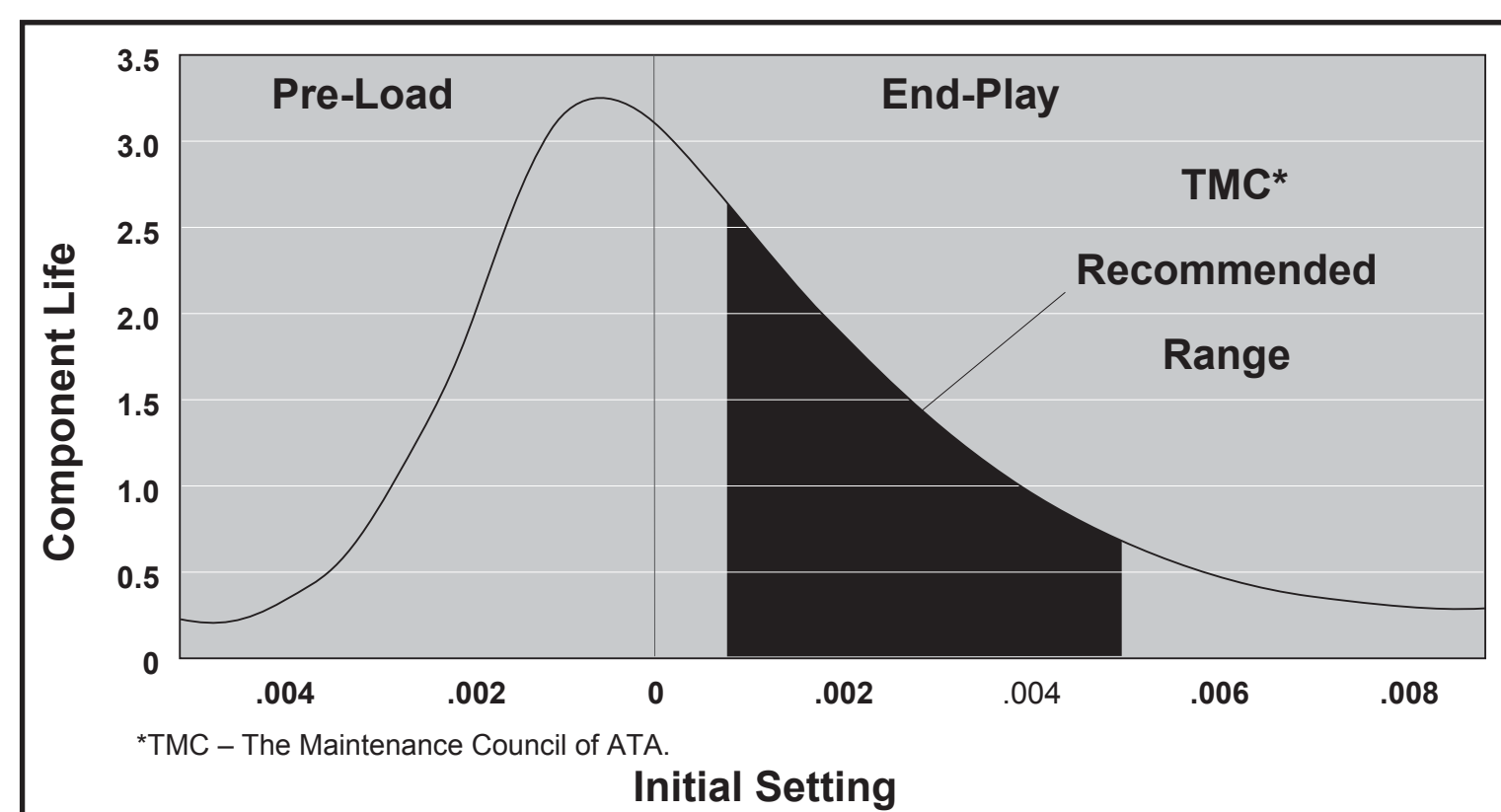

Recommended End Play Range  
FIGURE 5.

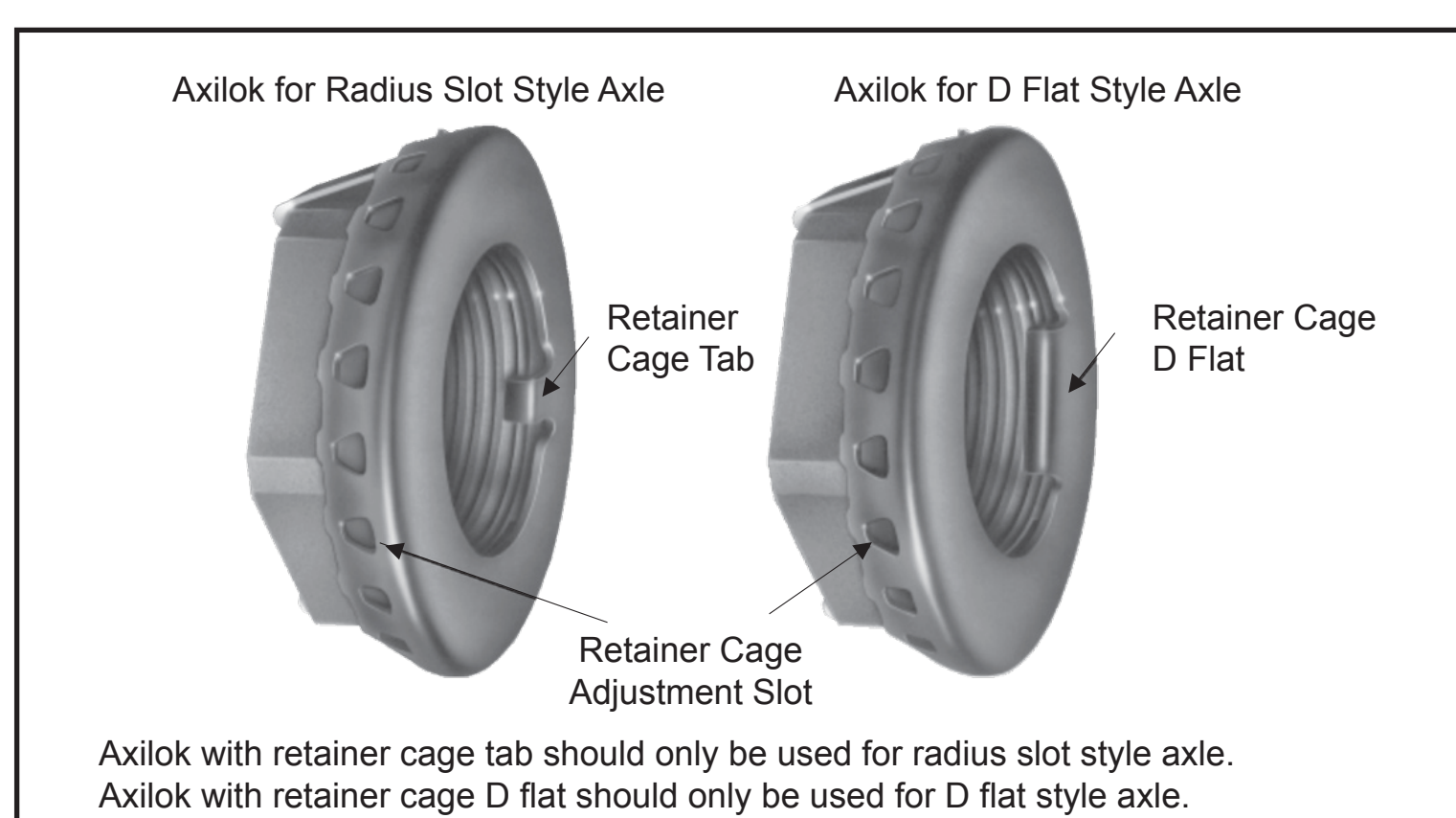

Axilok Styles  
FIGURE 6.

### Installation Procedure

#### NOTE

When using the Axilok product with a bearing containing an internal spacer, follow the original equipment manufacturer's torque specification. Ensure locking clips protrude through the adjustment slots after applying torque. If locking clips do not protrude through the adjustment slots, rotate the Axilok product slightly clockwise. Refer to Figures 2, 3, and 4. If locking clips are broken or damaged, replace the Axilok product and repeat the installation instructions.

Equipment Required:

- Six-point socket, sized according to the markings stamped on the face of the Axilok. Refer to Figure 1 and Table 1.
- Torque wrench.
- Dial indicator.

1. Before installation, perform pre-installation checks:

- Be sure the spindle slot is clean and free of burrs and foreign material before installing Axilok.
- Be sure the thread size is the same on both components.
- Put a few drops of oil through one of the retainer cage holes. This will ensure friction-free movement.

2. Put Axilok in the correct size six-point socket (refer to Table 1) and verify that the locking clips are compressed. Refer to Figure 2. Retainer cage should spin freely.

3. Align Axilok retainer cage tab or "D" flat. Be sure to start and run down the Axilok by hand. Do not use power tools. Rotate the socket clockwise until contacting bearing. Refer to Figure 9.

4. Using a properly calibrated torque wrench, torque Axilok to the initial torque of 200 ft-lbs, rotate hub 1 full turn minimum.

- Re-Torque to 200 ft-lbs, rotate 1 full turn min.
- Back off 1/2 turn
- Torque to 75 ft-lbs, rotate 1 full turn min.
- Back off 1/10 turn (1 wheel stud) Check Endplay. Refer to Figure 10.

5. Remove socket and verify locking clip tabs have engaged the adjustment slots in the retainer cage. Refer to Figures 2, 3, and 4.

6. Measure end play using a dial indicator. If correct end play is not achieved, adjust according to adjustment increments shown in Table 1.

- Rotate Axilok clockwise to reduce end play. (Example: from 0.004" to 0.002" end play.)
- Rotate Axilok counterclockwise to increase end play. (Example: from 0.001" to 0.003" end play.)
- This same procedure can be used to achieve a controlled pre-load condition. (Example: from 0.001" end play to 0.001" pre-load.)

7. After end play adjustment, make sure that both locking clip tabs are protruding through the slots in the retainer cage. Refer to Figures 2, 3, and 4.

### WARNING

Failure to observe the following warnings can result in separation of the wheel from the vehicle, creating a risk of death or serious injury.

Proper maintenance and handling practices are critical. Always follow installation instructions and maintain proper lubrication.

Do not use this Axilok product if locking clips are broken or damaged.

Always inspect the installation of the Axilok product when it is completed to ensure that locking clip tabs protrude through the adjustment slots.

If locking clip tabs do not protrude through the adjustment slots, rotate Axilok slightly clockwise. Refer to Figures 2, 3, and 4. If locking clip(s) are broken, replace Axilok and repeat installation procedures.

### Removal Procedure

#### NOTE

Do not use chisel, hammer or any power tool to remove the Axilok product.

Equipment Required:

- Six-point socket, sized according to the markings stamped on the face of the Axilok. Refer to Figure 1 and Table 1.
- Torque wrench.

1. Install correct size six-point socket completely over the hex of the Axilok. Be sure that both the locking clips are completely disengaged from the retainer cage, permitting free rotation. Refer to Figure 2.

2. Turn counterclockwise to remove Axilok. If Axilok does not move freely, stop removal. Check that the socket is completely and fully engaged on the Axilok and that the locking clips are fully retracted from the retainer cage slots. If Axilok still will not turn freely, rotate slightly clockwise to tighten, and then loosen again. The nut should rotate counterclockwise freely.

3. Continue counterclockwise rotation until Axilok threads disengage from the spindle threads.



**Axilok**  
is manufactured by  
METFORM, LLC  
A Division of MacLean-Fogg Component Solutions